



Setup Instructions for an Unlimited Awnings Awning

Congratulations on your purchase of an Unlimited Awnings product for your trailer. You have purchased a quality product that provides the *quickest, trouble free setup* in the industry! We ARE taking awnings to the next level.

Following are general guidelines for setting up an Unlimited Awnings awning on your trailer. Please contact us at 612-816-9644 or info@unlimitedawnings.com with any questions, comments or concerns.

Please refer to your Installation and/or Approval drawing for specific details on your awning. Read the entire setup guide before setting up your awning for the first time.

Depending on your specific configuration, some tubes and/or frame assemblies may not be interchangeable (example: if a frame assembly could interfere with a door opening, it will be different than the rest).

These instructions refer to the “first” as referenced from the rear of the trailer when the awning is mounted on the passenger side. When mounted on the driver side, “first” refers to the front of the trailer.

All components of the awning **must be setup and installed** correctly for proper operation of the awning.

Install Quick Connects Tube Frames To Trailer (Quick Connect Style)

1. Set the Quick Connect end of the first lower frame tube at approximately 60° to ground just above the first lower frame bracket. **Fig. 1** Lower the bar straight down into the bracket. The pin on the bracket must slide into the cam groove on the Quick Connect tube end. **Fig. 2**
2. Install the first upper frame tube in the same way.
3. Repeat for remaining lower and upper frame tubes.

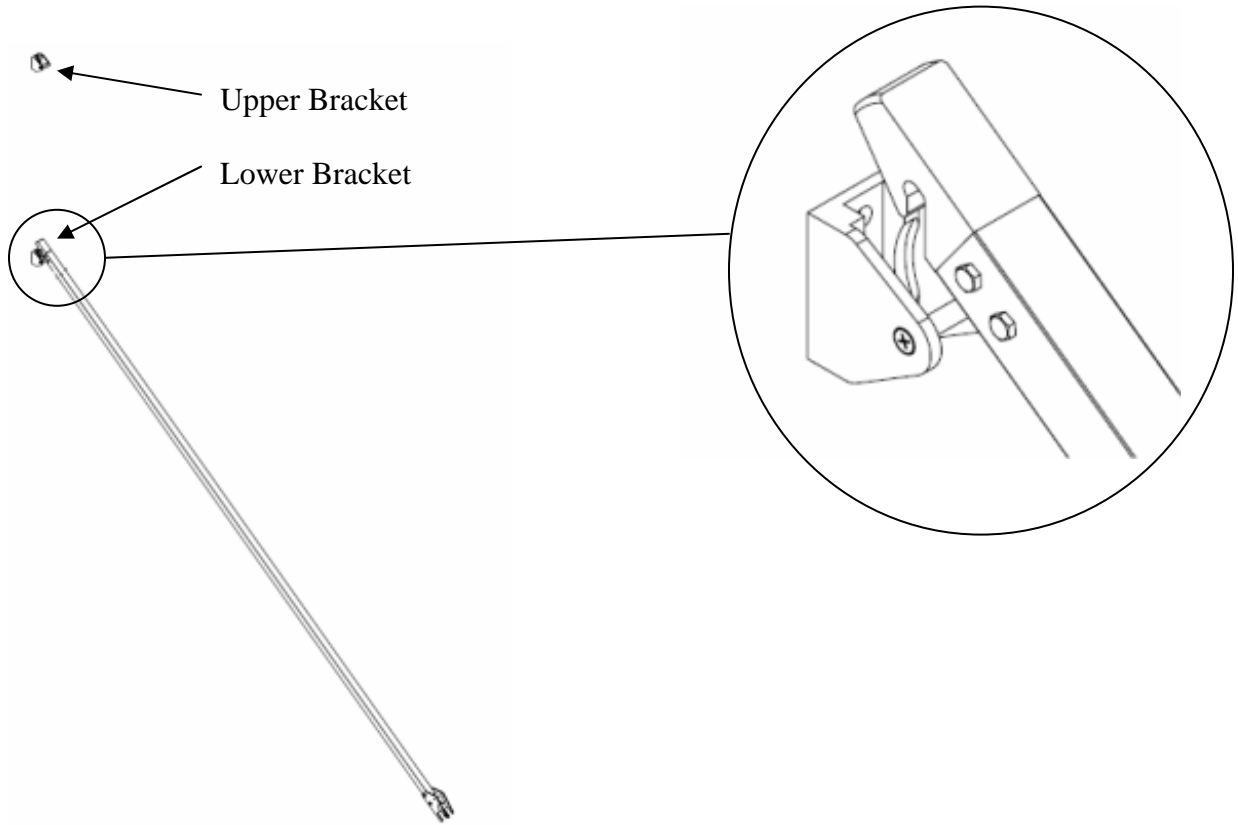

Figure 1 - Prepare to install Quick Connect tube onto trailer bracket

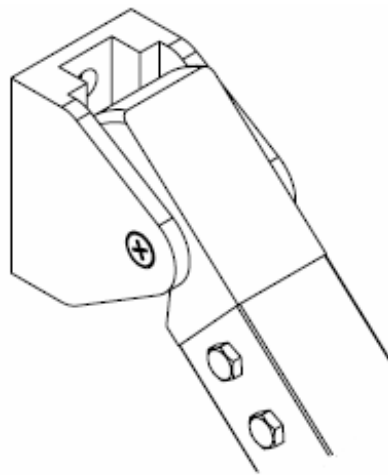

Figure 2 - Quick Connect tube preliminarily installed on trailer bracket

Install Upper and Lower Tube Frames Together (Quick Connect Style)

1. Starting with the first frame assembly, rotate the upper frame tube and the lower frame tube (about the pins installed in the trailer brackets) until the hole in the end of upper frame tube aligns with the hole on the side plates of the lower frame tube. **Fig 3** Note that special frame assemblies (ie above door openings, etc...) may be slightly different. The side plate may be attached to the upper tube frame and the lower tube frame may attach (by quick pin) to an intermediate bracket installed on the upper frame tube.
2. Insert quick pin through the side plate of lower frame tube and the hole in the upper frame tube.
3. Repeat for remaining frame assemblies.

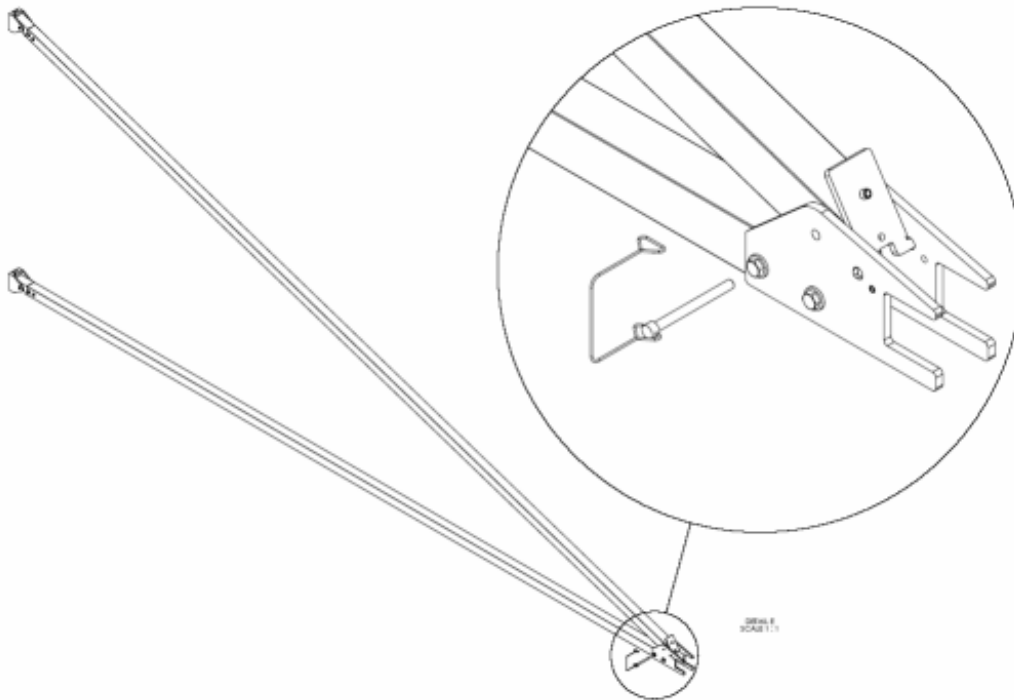

Figure 3 - Attach lower frame tube to upper frame tube

Install Tube Frames to Trailer and Attach Together (Quick Pin Style)

1. Set end of lower tube frame into trailer bracket and insert quick pin.
2. Set end of upper tube frame into trailer bracket and insert quick pin.
3. Rotate tubes together and install quick pin as described in previous section.
4. Alternatively, the upper and lower tubes can be installed as an assembly.

Install Front Bar to Tube Frame Assemblies

1. Ensure all toggle latch plates are in the open position (**Fig 4**) before installing the front bars. Note the front bars are generally all the same length except for possibly the last section. These pieces must be installed in the correct order so the tab on the latch plate (when pivoted down) fits into the corresponding hole on the front bar. This IS REQUIRED for proper operation of the awning. The ends of each tube are stamped with a consecutive number (1 starts at the rear of the trailer, unless mounting on drivers side, then 1 starts at the front of the trailer). The holes on the front bar **MUST BE** on the top surface when installed.
2. Since a front bar tube is typically longer than the distance between a frame section, only one piece at a time needs to be installed. The remaining tubes slide onto the stub of the previous tube.
3. Install the first front bar tube as shown in **Fig 4**
4. Flip the toggle latch to the down position to hold the front bar in place. The stub on the latch **MUST BE** located into the hole on the top side of the front bar for proper operation. **Fig 5**
5. Slide the next front bar tube onto the stub of the previous tube and repeat above until all front bars are installed.
6. The awning frame is now completely installed and is ready for the awning cover.

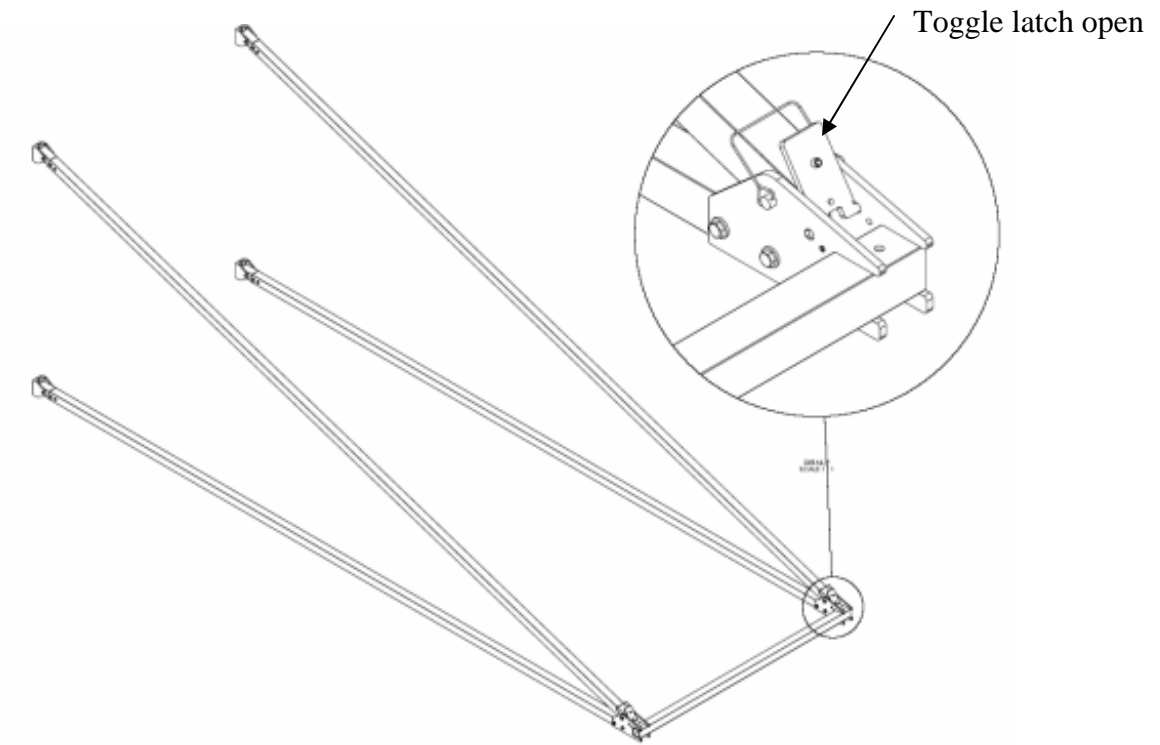

Figure 4 - Front bar installation

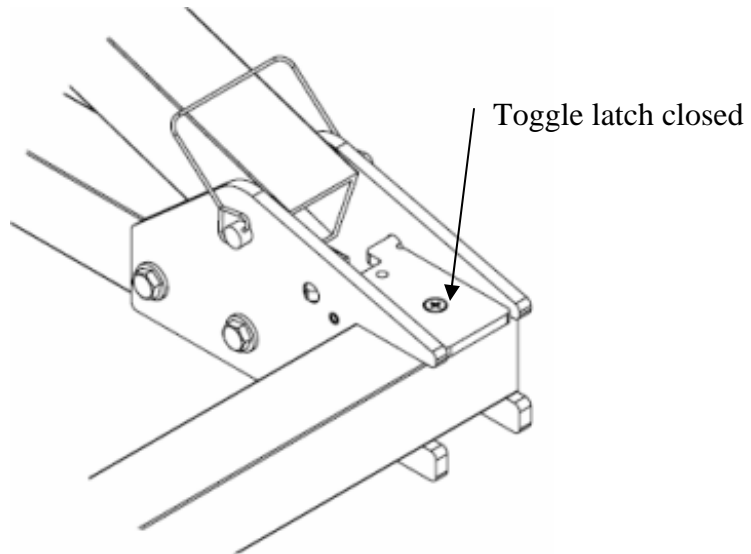

Figure 5 - Front bar toggle latch down position



Install Awning Cover Over the Awning Frame

1. Install the awning welt (with zipper half) into the awning rail mounted on the trailer (welt slides into awning rail). Ensure the start of the zipper is on the same end of the trailer as the start of the zipper on the awning cover.
2. Zipper the awning cover to the welt/zipper installed in the previous step.
3. Pull awning cover over frame assembly and attach straps around the front bar and the lower frame tube on each end section. Do not over tighten straps.

Leg Assembly (Optional)

1. Install adjustable leg pad into bottom of leg (height will be determined after the leg is installed into the frame). Retain with quick pin.
2. Install horizontal stub end of leg into lower frame tube (between plates), until the hole on the top of the leg assembly aligns with the hole on plate.
3. Install quick pin.

Dis-assembly of Awning Cover and Awning Frame

1. Disassembly of the awning is in the reverse order of assembly.